



UL INTERNATIONAL (UK) LTD  
 Womersley House, Building C,  
 The Guildway,  
 Old Portsmouth Road,  
 Guildford. GU3 1LR.  
 United Kingdom.



designated according to Article 29 of the Regulation (EU) No 305/2011 and member of EOTA (European Organisation for Technical Assessment, [www.eota.eu](http://www.eota.eu))

## European Technical Assessment

## ETA 17/1021 of 21/12/2017

**Technical Assessment Body issuing the ETA and designated according to Article 29 of the Regulation (EU) No 305/2011: UL International (UK) Ltd**

**Trade name of the construction product**

K-FLEX K-FIRE COATING

**Product family to which the construction product belongs**

Fire Stopping and Sealing Product:  
 • Linear Joint and Gap Seals

**Manufacturer**

L'ISOLANTE K-FLEX S.p.A.  
 Via Don G. Locatelli 35  
 20877  
 Roncello  
 MB Italy

**Manufacturing plant(s)**

A/003

**This European Technical Assessment contains**

10 pages including 1 Annex which forms an integral part of this assessment.

**This European Technical Assessment is issued in accordance with regulation (EU) No 305/2011, on the basis of**

ETAG 026-3, edition 2011, used as European Assessment Document (EAD)

Translations of this European Technical Assessment in other languages shall fully correspond to the original issued document and should be identified as such.

Communication of this European Technical Assessment, including transmission by electronic means, shall be in full. However, partial reproduction may be made, with the written consent of the issuing Technical Assessment Body. Any partial reproduction has to be identified as such.

**Table of Contents**

**I. SPECIFIC PARTS OF THE EUROPEAN TECHNICAL ASSESSMENT** ..... 3

1 Technical description of the product ..... 3

2 Specification of the intended uses of the product in accordance with the applicable European Assessment Document (Hereinafter EAD): ETAG 026-2..... 3

3 Performance of the product and references to the methods used for its assessment ..... 5

4 ASSESSMENT AND VERIFICATION OF CONSTANCY OF PERFORMANCE (HEREINAFTER AVCP) SYSTEM APPLIED, WITH REFERENCE TO ITS LEGAL BASE..... 6

5 Technical details necessary for the implementation of the AVCP system, as provided for in the applicable EAD ..... 6

6 Issued on:..... 7

**ANNEX A – Resistance to Fire Classification – K-FLEX K-FIRE COATING**..... 8

A.1 Rigid floor constructions with thickness of minimum 150 mm..... 8

A.1.1 Linear joint or gap seal, between floor slabs or between floor slab and wall with coating to the both faces of seal ..... 8

A.1.2 Linear joint or gap seal, between floor slabs or between floor slab and wall with coating to the top face of seal only ..... 9

A.1.3 Linear joint or gap seal, between the head of walls (min. 150 mm thick) and the soffit of floor slabs or in walls (min. 150 mm thick) with coating to both faces ..... 10

## I. SPECIFIC PARTS OF THE EUROPEAN TECHNICAL ASSESSMENT

### 1 Technical description of the product

- 1) K-FLEX K-FIRE COATING is an ablative sealant coating designed to enhance, seal and fire protect mineral fibres. It is based on a durable polymer system with inert fillers, non-halogenated fire retardants and a preservative to resist microbial attack. K-FLEX K-FIRE COATING is a sprayed coating product that is site or factory applied to both faces of a stone wool, mineral fibre board or site applied to one face of stone wool mineral fibre backer, to form a linear joint seal system. The intended use of K-FLEX K-FIRE COATING is to reinstate the fire resistance performance of floor to floor/ floor to wall joints and wall gaps.
- 2) The K-FLEX K-FIRE COATING system, when factory applied/supplied is referenced K-FLEX K-FIRE BOARD 2-S.
- 3) The K-FLEX K-FIRE COATING on mineral fibre boards, shall only be applied to Paroc Pyrotech Slab 160 / Paroc FPS 160 stone wool mineral fibre boards, with a minimum 1 mm WFT. The WFT of the coating should be measured and verified at minimum 5 locations to ensure correct installation. The stone wool mineral fibre boards may be supplied by L'ISOLANTE K-FLEX S.p.A or may be sourced separately. Installation of the K-FLEX K-FIRE COATING / K-FLEX K-FIRE BOARD system shall be in accordance with L'ISOLANTE K-FLEX S.p.A installation instructions.
- 4) The K-FLEX K-FIRE COATING may also be applied to stone wool, mineral fibre with a density  $33 \text{ kg/m}^3$ .
- 5) The applicant has submitted a written declaration that K-FLEX K-FIRE COATING does not contain substances which have to be classified as dangerous according to Directive 67/548/EEC and Regulation (EC) No 1272/2008 and listed in the "Indicative list on dangerous substances" of the EGDS - taking into account the installation conditions of the construction product and the release scenarios resulting from there.

In addition to the specific clauses relating to dangerous substances contained in this European technical Assessment, there may be other requirements applicable to the products falling within its scope (e.g. transposed European legislation and national laws, regulations and administrative provisions). In order to meet the provisions of the Construction Products Regulation, these requirements need also to be complied with, when and where they apply.

- 6) The use category of K-FLEX K-FIRE COATING in relation to BWR 3 (Hygiene, health and environment) is IA1, S/W3

### 2 Specification of the intended uses of the product in accordance with the applicable European Assessment Document (Hereinafter EAD): ETAG 026-2

Detailed information and data is given in Annex A.

- 1) The intended use of K-FLEX K-FIRE COATING is to reinstate the fire resistance performance of gaps in and joints between rigid floors and between rigid floors and rigid wall constructions, gaps in and joints between rigid floor constructions.
- 2) The specific elements of construction that the system K-FLEX K-FIRE BOARD may be used to provide a linear joint or gap seal in, are as follows:
  - a. Rigid floors: The floor must have a minimum thickness of 150 mm and comprise aerated concrete or concrete with a minimum density of  $650 \text{ kg/m}^3$ .

- b. Rigid walls: The wall must have a minimum thickness of 150 mm and comprise concrete, aerated concrete or masonry, with a minimum density of 650 kg/m<sup>3</sup>.

The supporting construction must be classified in accordance with EN 13501-2 for the required fire resistance period. (for details see Annex A)

- 3) The system K-FLEX K-FIRE COATING may be used to provide a linear joint or gap seal with specific supporting constructions and substrates (for details see Annex A).
- 4) The maximum permitted joint/gap width for system K-FLEX K-FIRE COATING is 120 mm.
- 5) The maximum movement capability of system K-FLEX K-FIRE BOARD is  $\leq 7.5\%$
- 6) The provisions made in this European Technical Assessment are based on an assumed working life of the K-FLEX K-FIRE COATING of 25 years, provided that the conditions laid down in the product datasheet for the packaging/transport/ storage/installation/use/repair are met. The indications given on the working life cannot be interpreted as a guarantee given by the producer, but are to be regarded only as a means for choosing the right products in relation to the expected economically reasonable working life of the works.
- 7) Type Z<sub>2</sub>: Intended for uses in internal conditions with humidity lower than 85 % RH excluding temperatures below 0°C, without exposure to rain or UV.

### 3 Performance of the product and references to the methods used for its assessment

Product-type: Coating		Intended use: Linear Joint & Gap Seal	
N°	Basic requirement for construction work	Essential characteristic	Performance
Mechanical resistance and stability			
	-	None	Not relevant
Safety in case of fire			
1	EN 13501-1	Reaction to fire	No performance assessed
2	EN 13501-2	Resistance to fire	Annex A
Hygiene, health and environment			
3	EN 1026:2000	Air permeability (material property)	No performance determined
4	ETAG 026-3, Annex C	Water permeability (material property)	No performance determined
5	Declaration of manufacturer	Release of dangerous substances	Declaration of manufacturer
Safety in use			
6	EOTA TR 001:2003	Mechanical resistance and stability	No performance determined
7	EOTA TR 001:2003	Resistance to impact/movement	No performance determined
8	EOTA TR 001:2003 ISO 11600	Adhesion	No performance determined
Protection against noise			
9	EN 10140-2/ EN ISO 717-1	Airborne sound insulation*	R <sub>w</sub> (C;Ctr) = 55 (-1;-1) dB
10	EN 10140-3/ EN ISO 717-2	Impact sound insulation	No performance determined
Energy economy and heat retention			
11	EN 12664, EN 12667 or EN 12939	Thermal properties	No performance determined
12	EN ISO 12572 EN 12086	Water vapour permeability	No performance determined
General aspects relating to fitness for use			
13	EN 13162 or EN 14303, EN ISO 1519	Durability and serviceability	Z <sub>2</sub>

\* K-FLEX K-FIRE COATING 1.0mm WFT on both sides of minimum 50mm thick stone wool mineral fibre board with density minimum 160kg/m<sup>3</sup>

**4 ASSESSMENT AND VERIFICATION OF CONSTANCY OF PERFORMANCE (HEREINAFTER AVCP) SYSTEM APPLIED, WITH REFERENCE TO ITS LEGAL BASE**

According to the decision 1999/454/EC – Commission Decision of date 22nd June 1999 on on the procedure for attesting the conformity of construction products pursuant to Article 20(2) of Council Directive 89/106/EEC as regards fire stopping, fire sealing and fire protective products, published in the Official Journal of the European Union (OJEU) L178/52 of 14/07/1999, see <http://eur-lex.europa.eu/JOIndex.do>) of the European Commission<sup>1</sup>, as amended, the system(s) of assessment and verification of constancy of performance (see Annex V to Regulation (EU) No 305/2011) given in the following table(s) applies (apply).

<b>Product(s)</b>	<b>Intended use(s)</b>	<b>Level(s) or class(es)</b>	<b>System(s)</b>
Fire stopping and Fire Sealing Products	For fire compartmentation and/or fire protection or fire performance	Any	1

**5 Technical details necessary for the implementation of the AVCP system, as provided for in the applicable EAD**

Tasks of the manufacturer:

Factory production control

The manufacturer shall exercise permanent internal control of production. All the elements, requirements and provisions adopted by the manufacturer shall be documented in a systematic manner in the form of written policies and procedures, including records of results performed. This production control system shall ensure that the product is in conformity with this European technical Assessment.

The manufacturer may only use initial / raw / constituent materials stated in the technical documentation of this European Technical Assessment.

The factory production control shall be in accordance with the Control Plan of 26<sup>th</sup> June 2014 relating to the European technical assessment ETA 17/1021 issued on 21/12/2017 which is part of the technical documentation of this European technical assessment. The "Control Plan" is laid down in the context of the factory production control system operated by the manufacturer and deposited at UL International (UK) Ltd.

The results of factory production control shall be recorded and evaluated in accordance with the provisions of the Control Plan.

---

<sup>1</sup> Official Journal of the European Communities L178/52 of 14/7/1999

Other tasks of the manufacturer

Additional information

The manufacturer shall provide a technical data sheet and an installation instruction with the following minimum information:

(a) Technical data sheet:

- Field of application:
- Building elements for which the penetration seal is suitable, type and properties of the building elements like minimum thickness, density, and - in case of lightweight constructions – the construction requirements.
- Limits in size, minimum thickness etc. of the penetration seal
- Construction of the penetration seal including the necessary components and additional products (e.g. backfilling material) with clear indication whether they are generic or specific.
- Services which the penetration seal is suitable, type and properties of the services like material, diameter, thickness etc. in case of pipes including insulation materials; necessary/allowed supports/fixings (e.g. cable trays)

(b) Installation instruction:

- Steps to be followed
- Procedure in case of retrofitting
- Stipulations on maintenance, repair and replacement

**6 Issued on:**

**21<sup>st</sup> December 2017**

Report by:



D. Yates  
Project Engineer  
Building and Life Safety Technologies

Reviewed by:



C. Johnson  
Staff Engineer  
Building and Life Safety Technologies

**For and on behalf of UL International (UK) Ltd.**

## ANNEX A – Resistance to Fire Classification – K-FLEX K-FIRE COATING

### A.1 Rigid floor constructions with thickness of minimum 150 mm

#### A.1.1 Linear joint or gap seal, between floor slabs or between floor slab and wall with coating to the both faces of seal

**Joint Seal:** 60mm thick K-FLEX K-FIRE BOARD 60 2-S friction fitted at any position fully within the cavity\* and sealed at the joint and along the top and bottom edges with K-FLEX K-FIRE ACRYLIC

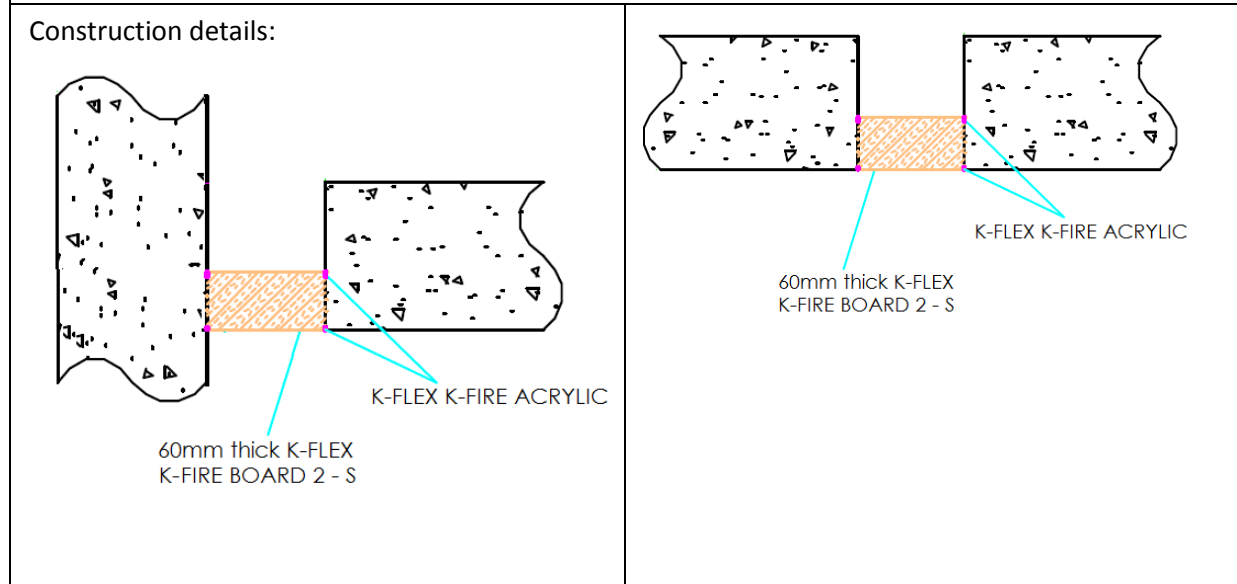

#### A.1.1.1

Substrate	Depth (mm)	Backing	Classification
masonry/ concrete	1 mm WFT min. Both sides	60 mm stone wool, mineral fibre batt	<b>E 240 – H – X – F – W30-120</b> <b>EI 120 – H – X – F – W30-120</b>



**A.1.2 Linear joint or gap seal, between floor slabs or between floor slab and wall with coating to the top face of seal only**

**Joint Seal:** 100mm thick Stone wool, mineral fibre insulation friction fitted at least 50 mm above the soffit and coated on the top face with K-FLEX K-FIRE COATING

Construction details:

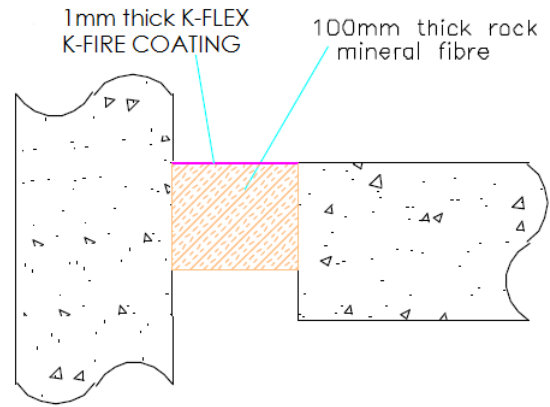
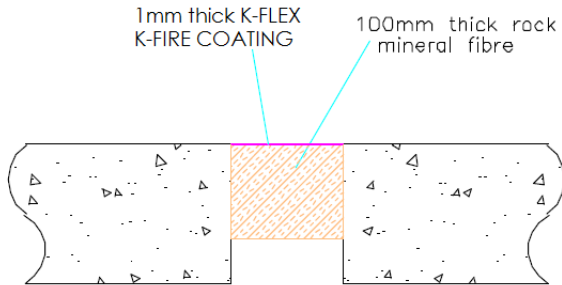

**A.1.2.1**

Substrate	Depth (mm)	Backing	Classification
masonry/ concrete	1 mm WFT min. top face	100 mm stone wool, mineral fibre min. 33 kg/m <sup>3</sup>	<b>E 240 – H – X – F – W120</b> <b>EI 180 – H – X – F – W120</b>

**A.1.3 Linear joint or gap seal, between the head of walls (min. 150 mm thick) and the soffit of floor slabs or in walls (min. 150 mm thick) with coating to both faces**

**Joint Seal:** 100mm thick Stone wool, mineral fibre insulation compression fitted to either face of the wall or at any position in between and coated on both faces with K-FLEX K-FIRE COATING

Construction details:

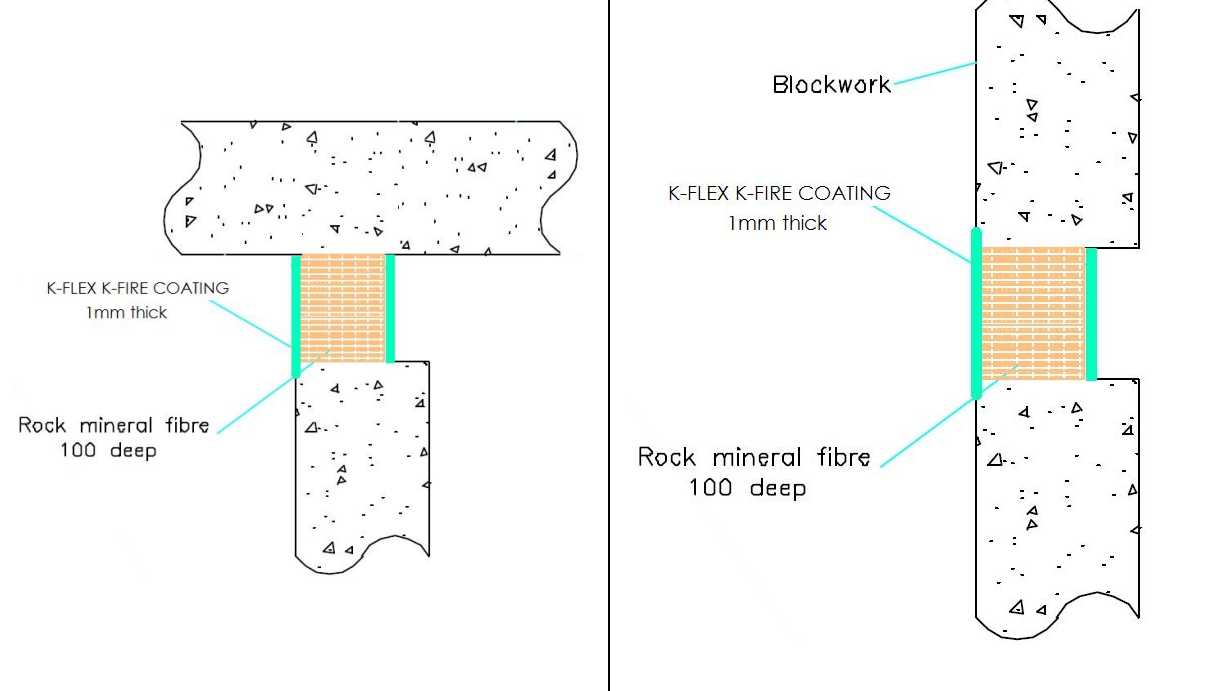

**A.1.3.1**

Substrate	Depth (mm)	Backing	Classification
masonry/ concrete	1.2 mm WFT min. both faces overlapped by 15 mm onto wall surface	100 mm stone wool, mineral fibre min. 35 kg/m <sup>3</sup> , compressed into gap by 40%	<b>E 240 – T – X – F – W120</b> <b>EI 180 – T – X – F – W120</b>